

## Smart Jumbo Twister 迈特大卷装倍捻机

**MAGN**  
苏州英迈杰机械有限公司

地址：江苏省苏州工业园区唯文路7号A幢

Add: Block A.No.7 Weiwen Road,Suzhou Industrial park,Suzhou,Jiangsu,China

电话：0512-67066492

Tel : 0512-67066492

传真：0512-67066493

Fax : 0512-67066493

网址：www.imaginsz.com

Http: //www.imaginsz.com

■本样本仅作参考，不作为技术验收依据。

■为提高产品质量，本公司保留更改规格之权力，恕不另行通知。

■We reserve the right to modify the characteristics of the machines described herein without prior notice

■The data given in this brochure are not intended as a guarantee.

**苏州英迈杰机械有限公司**  
Suzhou Imagin Machinery Co.,Ltd.

## 机器截面图

### Machine cross section

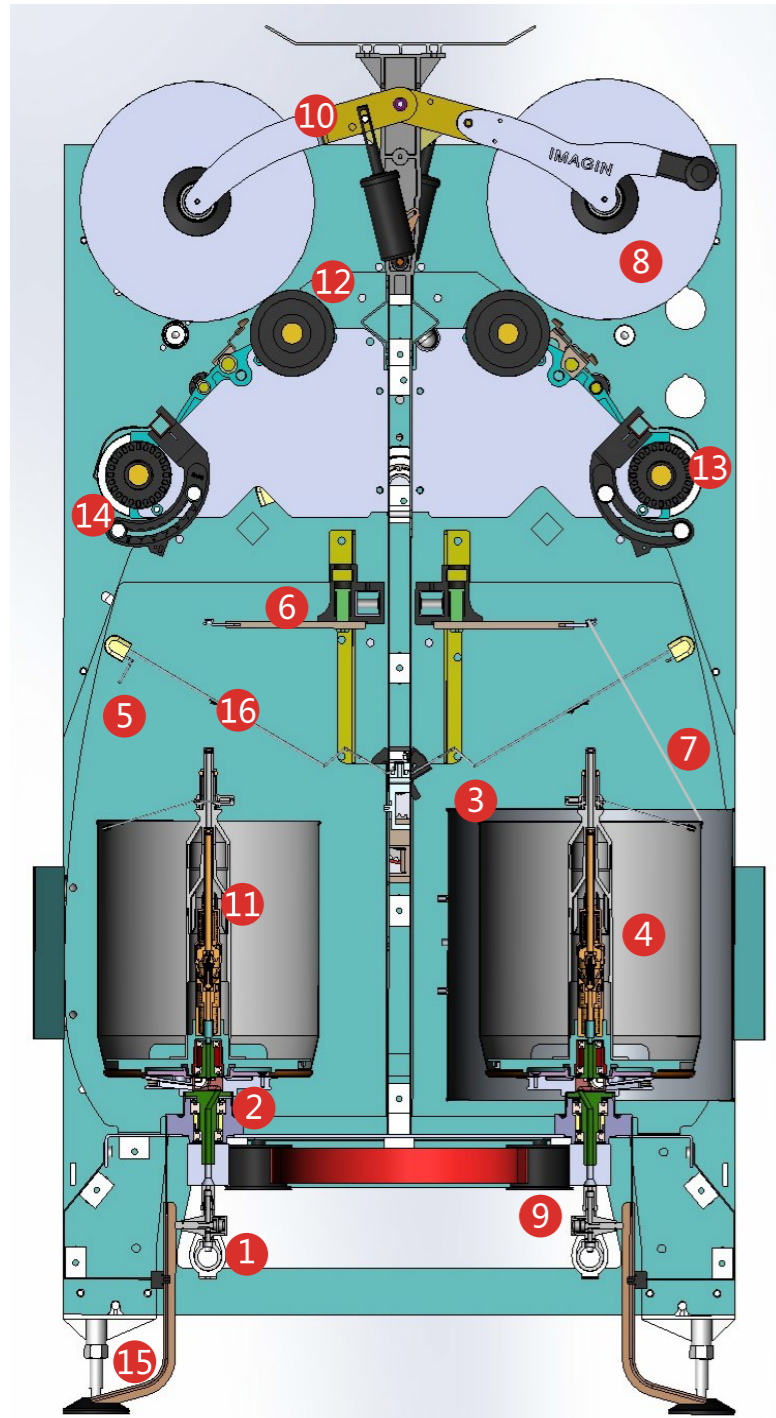

- |   |       |                      |
|---|-------|----------------------|
| ① | 穿线阀   | Threading valve      |
| ② | 锭子    | Spindle              |
| ③ | 气圈罩   | Balloon limiter      |
| ④ | 多级张力器 | Multi-tension device |
| ⑤ | 隔纱板   | Separator            |
| ⑥ | 导纱钩   | Yarn guide           |
| ⑦ | 气圈    | Yarn balloon         |
| ⑧ | 筒纱    | Yarn package         |
| ⑨ | 压轮    | Press roller         |
| ⑩ | 摇架    | Cradle               |
| ⑪ | 锭罐    | Spindle pot          |
| ⑫ | 摩擦辊   | Friction roller      |
| ⑬ | 超喂罗拉  | Pre-take-up roller   |
| ⑭ | 导纱罗拉  | Deflection roller    |
| ⑮ | 刹车板   | Foot pedal           |
| ⑯ | 断纱探杆  | Yarn feeler          |

## 迈特大倍捻机

### Smart Jumbo Twister

#### 01 Save 节能

- ▲ e-save 锭子  
e-save spindle
- ▲ 新驱动系统  
New driving concept
- ▲ 气圈罩  
Balloon limiter

#### 02 Maintenance 简易的维护

- ▲ 可靠性强  
Reliability
- ▲ 装机时间短  
Short installation time

#### 03 Automation 自动化

- ▲ PLC 集中控制  
PLC centralized control
- ▲ 一键工艺设定  
Just set all parameters in touch screen
- ▲ 气圈高度集中调节  
Central adjustment for balloon height
- ▲ 超喂包围角集中调节  
Central adjustment for deflection rollers
- ▲ 灵活的筒子成型  
Flexible package formation

#### 04 Technology 高技术

- ▲ 新型的伺服驱动系统  
New driving concept
- ▲ 断电保护功能

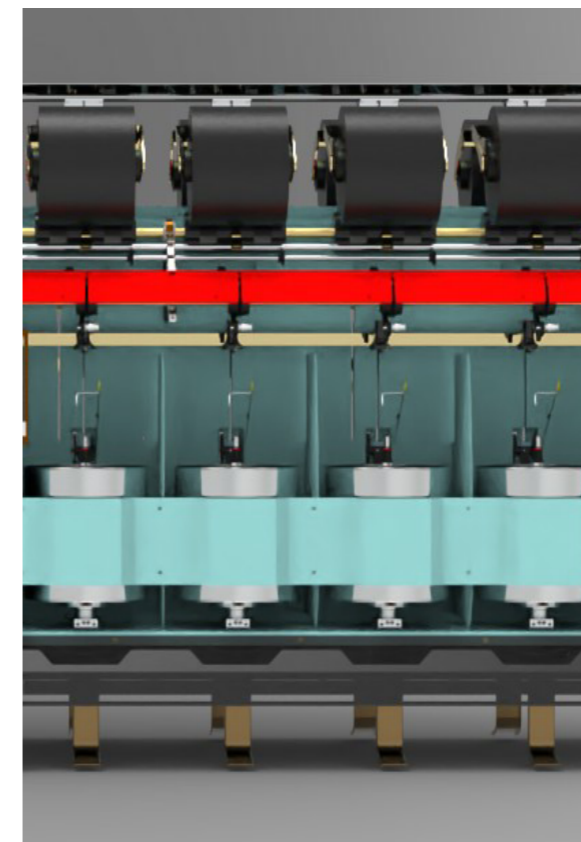

## 传动方式 Transmission

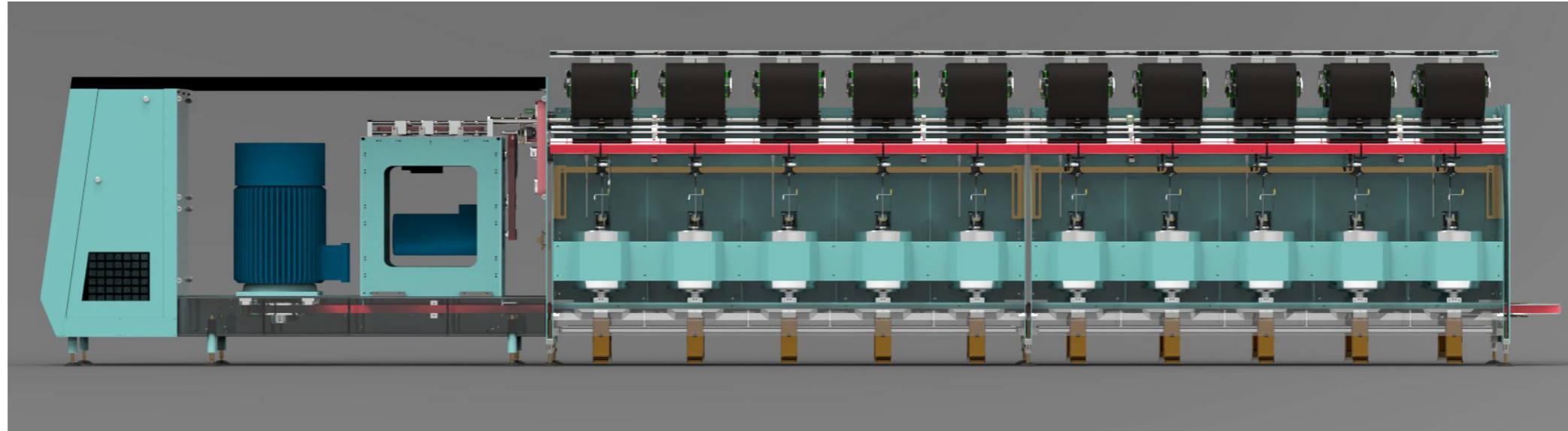

## 伺服驱动

### 驱动单元

- ▲ 锭子伺服电机：驱动锭子
- ▲ 小电机：驱动卷绕
- ▲ 横动伺服电机：驱动横动

PLC将这些电机以设定的速比运行，确保机器在运行和启停阶段的捻度一致，控制面板通过控制伺服驱动器，确保启停状态的捻度不变。断电的情况下，在PLC 伺服驱动器的同步作用下，有序的停止确保捻度一致。

## Servo Technology

### Driving unit

- ▲ Spindle servo motor: drive spindle
- ▲ Slave motor: take-up-rollers
- ▲ Traverse servo motor: drive traverse

PLC will run these motors at the set speed ratio to ensure the consistency of the machine during the running and start-stop phases. the control panel ensures that the twist of the single spindle start and stop state is constant by controlling the servo drive. Power outage Under the synchronous action of PLC servo drive, the orderly stop ensures the uniformity of the twist.



## 节能锭子 E - Save spindle

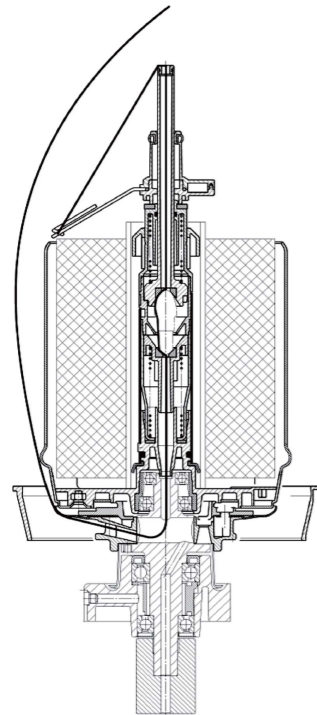

- ▲采用e-save结构锭子，极大的节约能源
- ▲锭速可达6000r/min，极大的提高了大卷装加捻效率
- ▲锭速监控功能，确保了更好的加捻质量
- ▲空心锭子设计，气动穿线，简单快捷
- ▲纱线通道均经过特殊处理，有效的保护纱线
- ▲锭子型号包括：SIM-05/SIM-06
- ▲Using e-save structure spindles, saving energy
- ▲Spindle speed up to 6000r/min, greatly improving the efficiency of large package
- ▲Spindle speed monitoring function ensures better twisting quality
- ▲Hollow spindle design, pneumatic threading, simple and fast
- ▲The yarn passages are specially treated to effectively protect the yarn
- ▲Spindle model includes: SIM-05/SIM-06

## 伺服驱动 Servo Technology

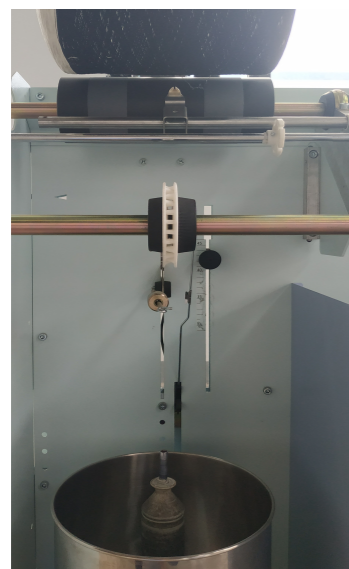

伺服卷取可以实现：

- ▲卷取速度可达120m/min。
- ▲一键设定参数，灵活设置。
- ▲电子防叠，电子松边。
- ▲传动和卷取完全隔开，免污染。

Servo coiling can be achieved:

- ▲The winding speed can reach 120m/min.
- ▲One-click setting parameters, single-turn temperature setting.
- ▲Electronic anti-stack, electronic loose edge.
- ▲The transmission and winding are completely separated to avoid pollution.

## 安装图 Layout

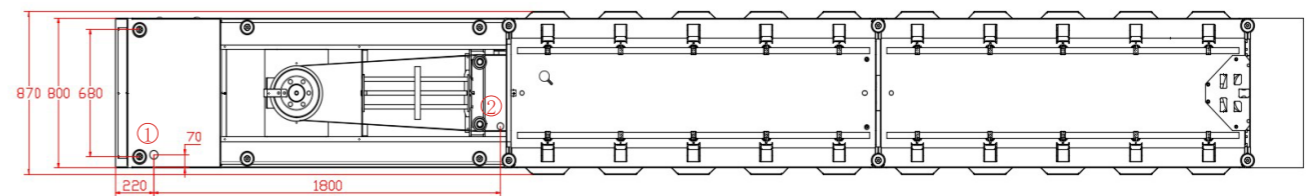
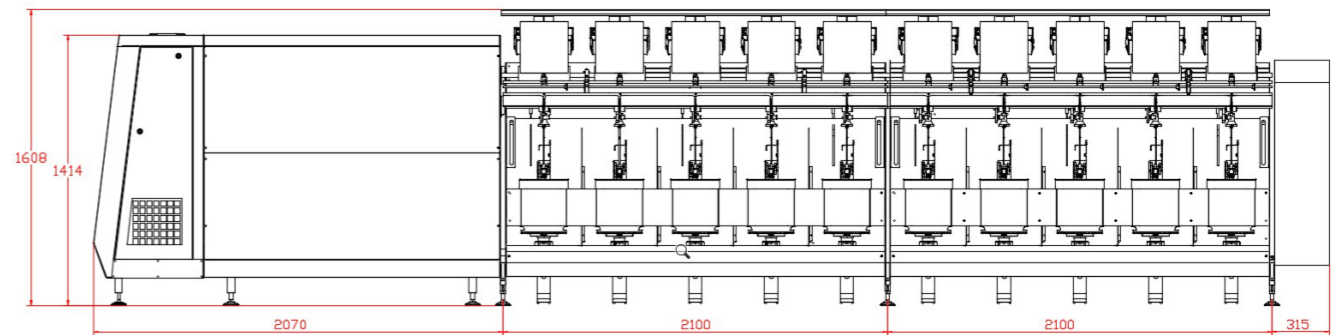

- ① 电气接口 Cable
- ② 压缩空气接口G1/2 air hose

SIM-05/SIM-06

机器节数 No. of sectims	1	2	3	4	5	6	7	8	9	10	11	12
锭距345mm Gauge of spindle	12	24	36	48	60	72	84	96	108	120	132	144
锭距414mm Gauge of spindle	10	20	30	40	50	60	70	80	90	100	110	120
总重量 ( N ) Total weight	11500	15500	19500	23500	27500	31500	35500	39500	43500	47500	51500	55500
总长度 ( mm ) Total length	4485	6585	8685	10785	12885	14985	17085	19185	21285	23385	25485	27585